

# Oncor Roscoe Area Upgrades Project

## Overview for ERCOT RPG Meeting 2/24/2025

Oncor Electric Delivery

WE DELIVER.



# Project Overview

- P6 contingencies cause low voltages in the area
- Oncor proposes the following system upgrades to reliably meet the a contracted load in the area:
  - 15 miles of greenfield 138 kV transmission line
  - 25 miles of 138 kV transmission line conversion
  - 1 new 138 kV load serving substation
  - Total cost of Proposed RPG Project - \$83 million

# Project Vicinity – Pre-Project

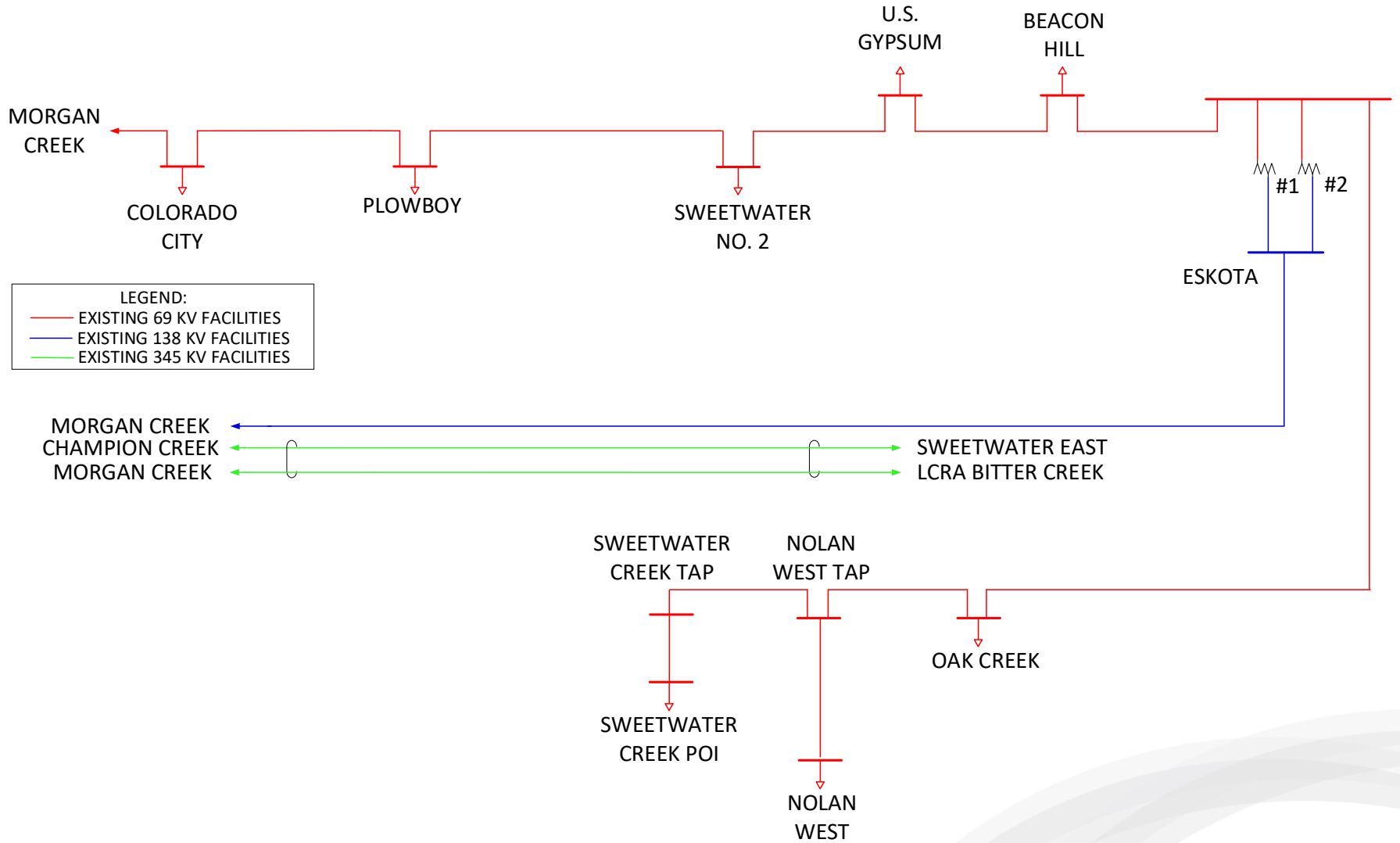

# Project Vicinity – Prerequisite Upgrades

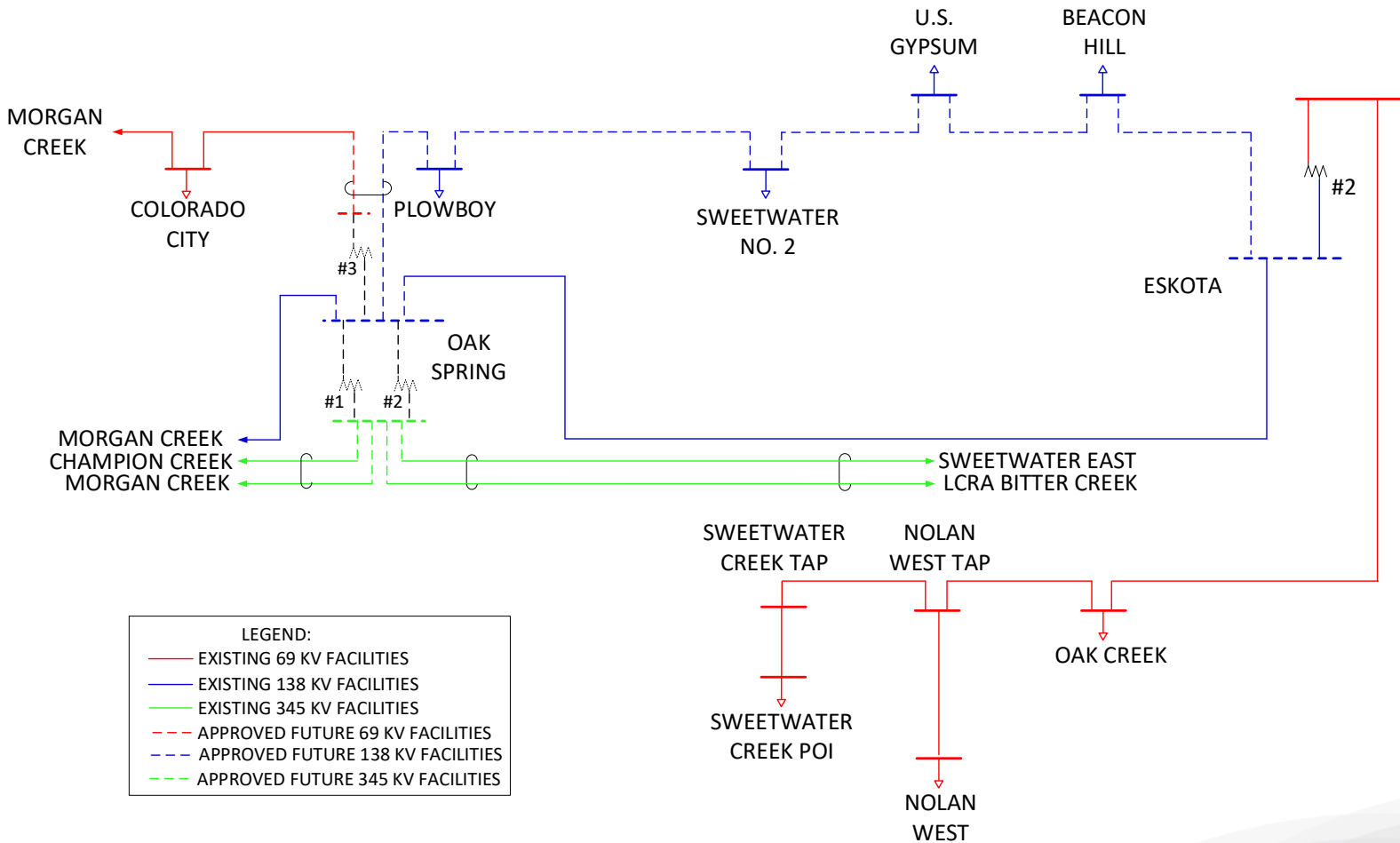

Part of the common local projects approved by the PUCT in October 2024

# Project Vicinity – Post-Project

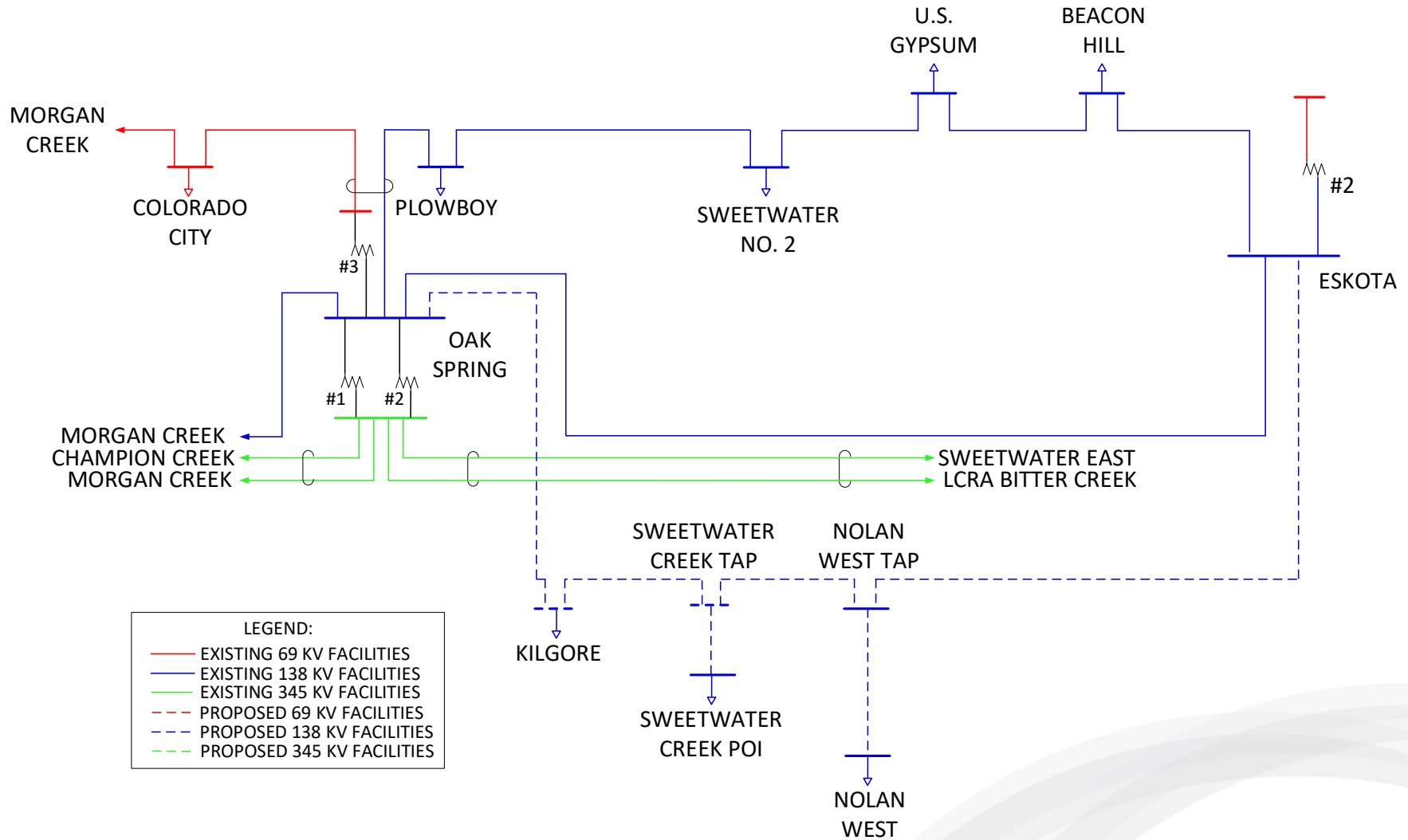

# Progress

- Anticipating multiple CCN applications/submittals (Tier 2)
- Construction expected to begin in 2026
- Anticipated to take 2 to 3 years to complete entire set of projects in the Proposed RPG Submittal
- Proposed RPG Submittal cleared RPG phase 1/16/2025
  - ERCOT Independent Review to be complete by 5/16/2025

# QUESTIONS

